

# KOI

Steh- und Tischleuchte  
Standing and table lamp  
Lampadaire et lampe de table  
Staande lamp en tafellamp  
Lampada a piantana e da tavolo

Montageanleitung  
Assembly Instructions  
Instruction de montage  
Montagehandleiding  
Istruzioni di montaggio



# KOI Stehlampe und Tischlampe

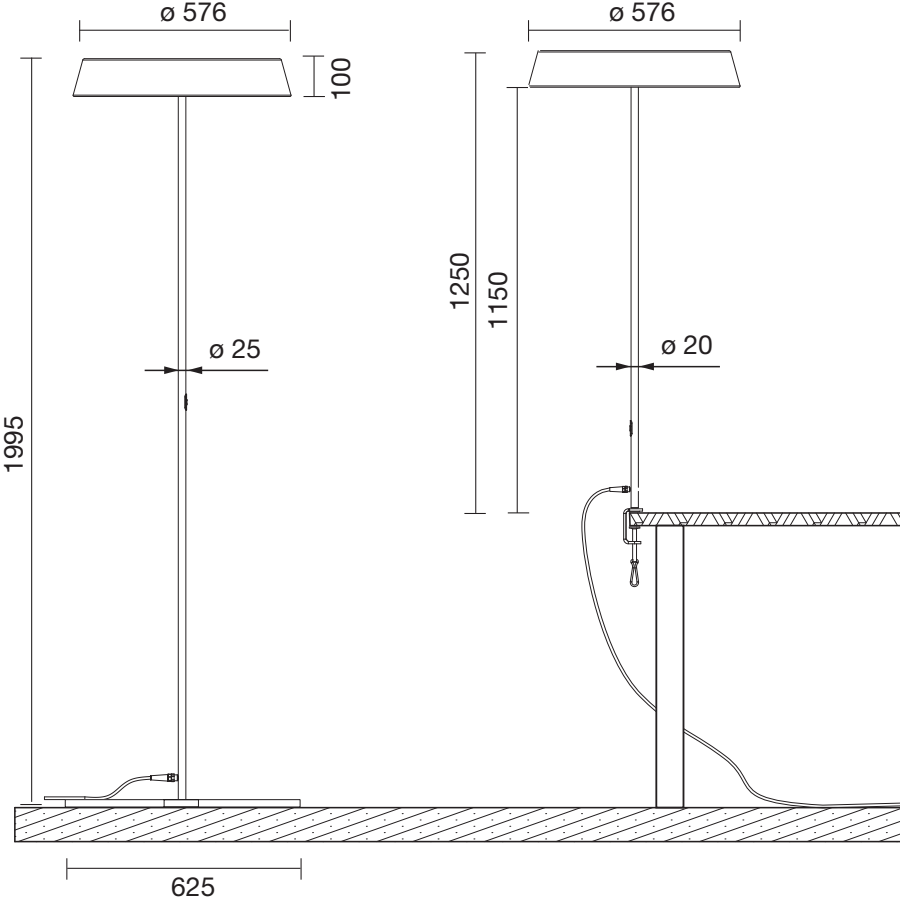

## Technische Hinweise

## Technical Information

## Indications techniques



- Beim Leuchtmittelwechsel immer Stromzufuhr durch Ausziehen des Steckers aus der Steckdose unterbrechen!

- When changing the illuminants, always disconnect the power supply by pulling the plug from the socket!!

- Lors du changement de l'ampoule, toujours couper l'alimentation électrique en débranchant la prise.



- Eingangsspannung 220-240V 50/60Hz

- Input voltage 220-240V 50/60Hz

- Tension d'entrée 220-240V 50/60Hz



- Leuchtmittel TC-TE 42W/840

- Lamp TC-TE 42W/840

- Ampoule TC-TE 42W/840



- Leuchten nur mit handelsüblichen, nicht aggressiven Reinigungsmitteln reinigen

- Use only commercially available non-aggressive cleaning agents for cleaning the lamps

- Ne nettoyer les lampes qu'avec des nettoyeurs non agressifs en vente dans le commerce

- Bitte reinigen Sie die Abdeckung ausschliesslich mit Wasser oder einem antistatischen Tuch. Alkohol, Benzol, Aceton oder Säuren können die Oberfläche beschädigen.

- Please clean the cover with water only or with an antistatic cloth. Alcohol, benzol, acetone or acids can damage the surface.

- Nettoyer le couvercle de recouvrement uniquement avec de l'eau ou un chiffon antistatique. L'utilisation d'alcool, de benzène, d'acétone ou d'acides peut endommager la surface.



- Leuchte darf nicht im Freien verwendet werden

- Lamp must not be used in the open

- Ne pas utiliser la lampe à l'extérieur



- Schutzklasse I

- Safety class I

- Classe de protection I



- Technische Konformität gemäss EN-Richtlinien

- Technical conformity according to European Standard guidelines

- Conformité technique selon les directives EN

## Technische aanwijzingen

## Informazioni tecniche



- Bij de wissel van verlichtingsmiddelen steeds stroomtoevoer onderbreken door de stekker uit het stopcontact te trekken!

- Quando si cambia la lampadina interrompere sempre l'alimentazione elettrica staccando la spina dalla presa!



- Ingangsspanning 220-240V 50/60Hz

- Tensione di alimentazione 220-240V 50/60Hz



- Lamp TC-TE 42W/840

- Lampadina TC-TE 42W/840



- Reinig de lampen uitsluitend met normale in de handel verkrijgbare, niet agressieve reinigingsproducten
- De afdekking uitsluitend reinigen met water of een antistatische doek. Alcohol, benzeen, aceton of zuren kunnen het oppervlak beschadigen.

- Pulire la lampada solamente con i normali detersivi non aggressivi che si trovano in commercio
- Pulire il corpo lampada solo con un panno antistatico. Alcool, acetone o altri agenti aggressivi possono danneggiare la superficie.



- De lamp mag niet in openlucht gebruikt worden

- La lampada non può essere utilizzata all'aperto



- Beschermingsklasse I

- Classe di protezione I



- Technische gelijkvormigheid volgens EN-richtlijnen

- Conformità tecnica secondo le Direttive EN

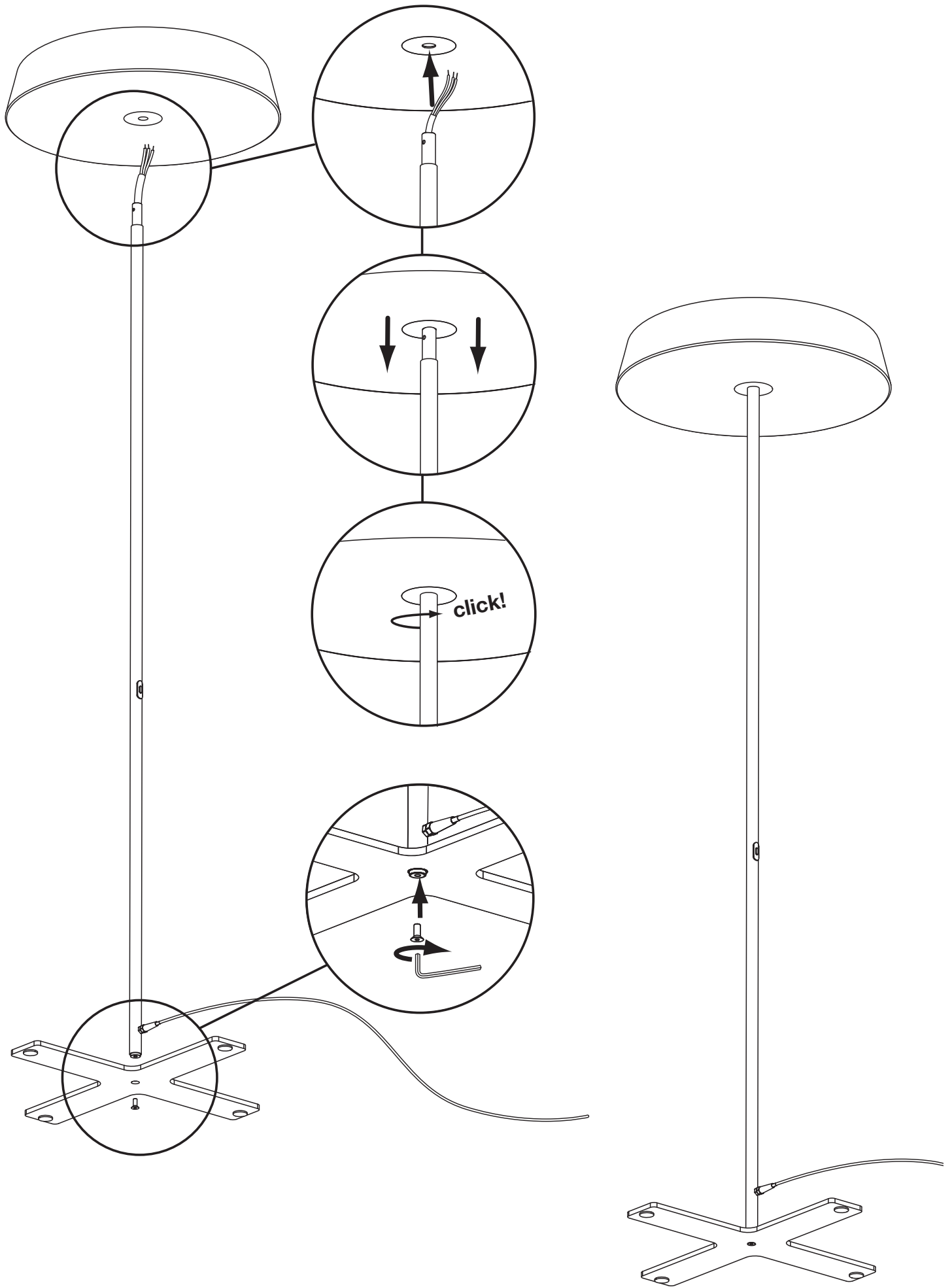

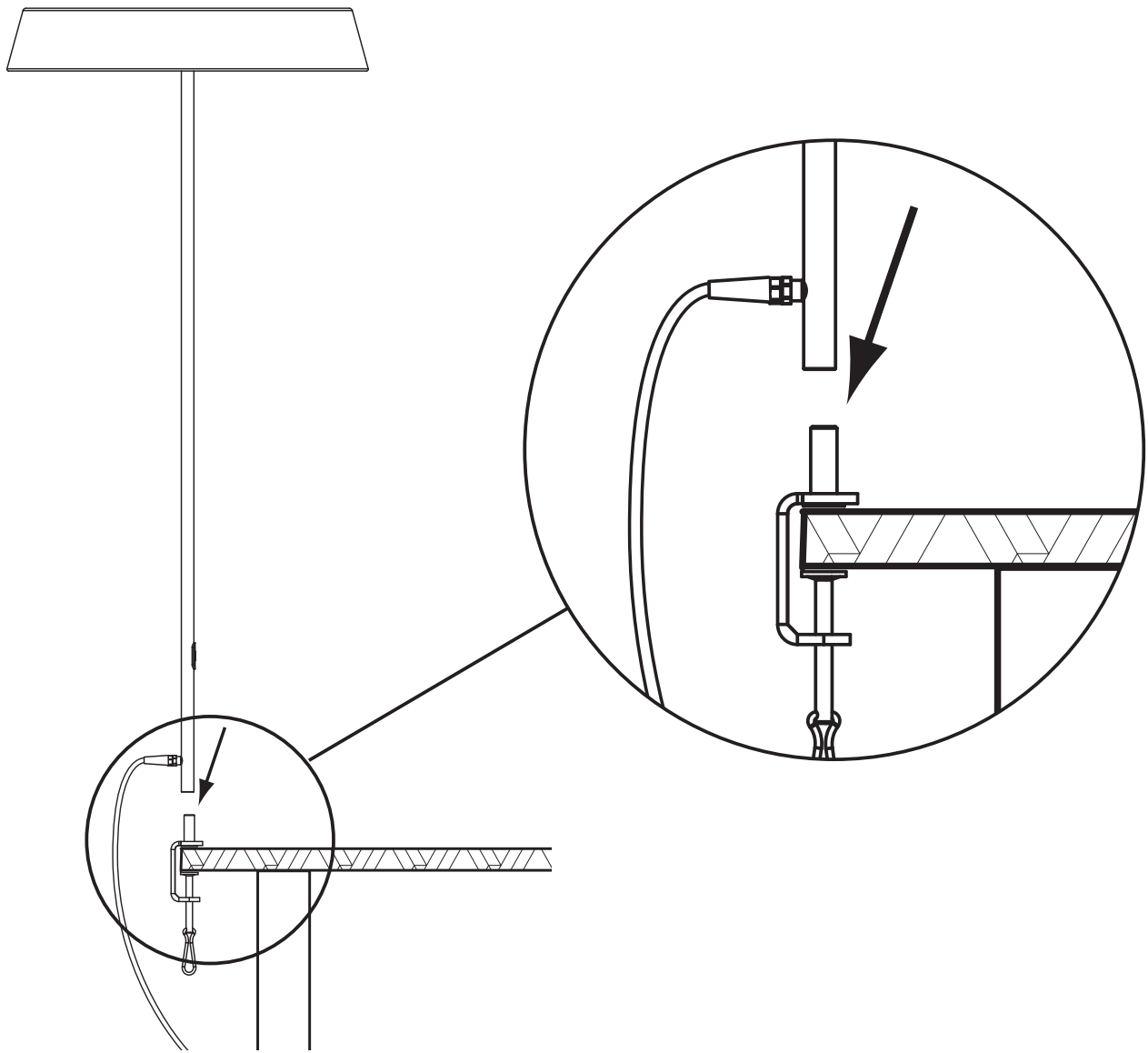

### 3 Pole

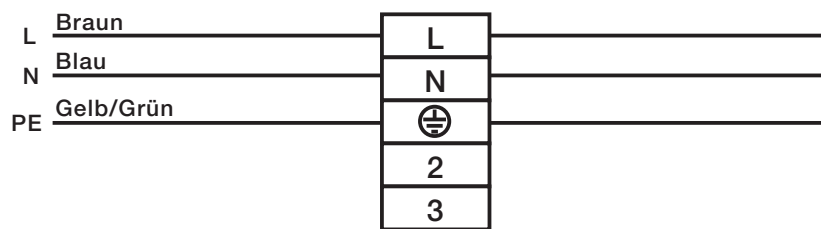
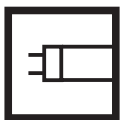

### 4/5 Pole Touchdim

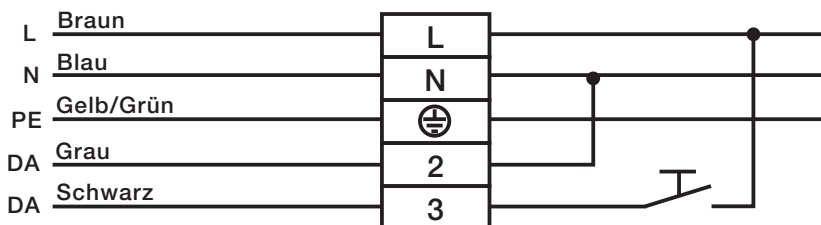
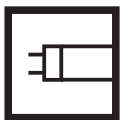

### 5 Pole DALI

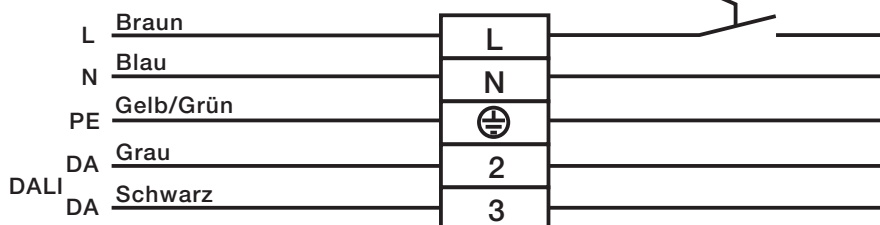

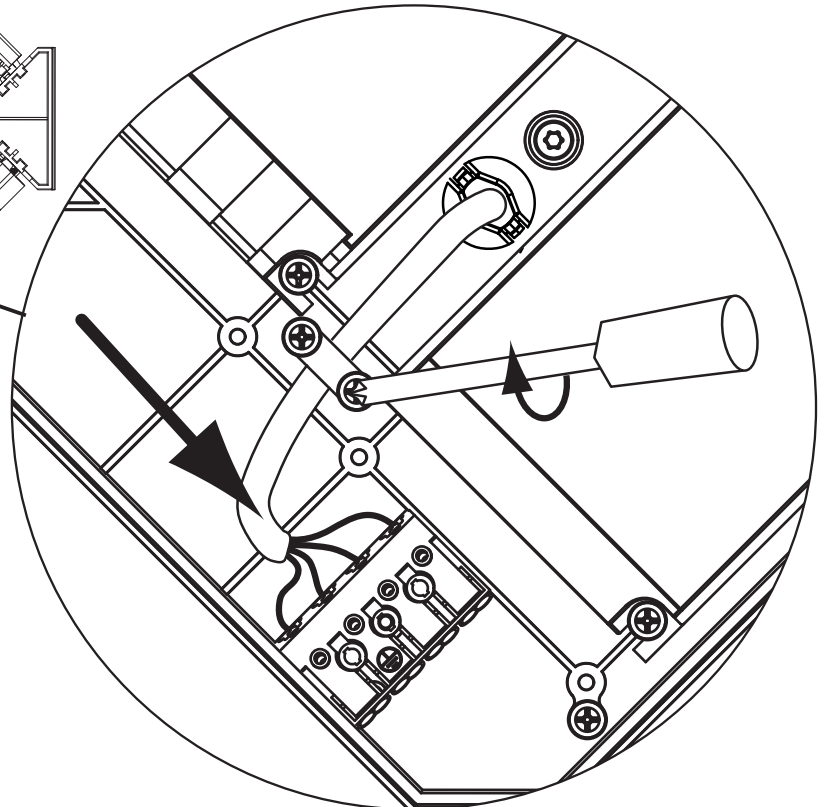
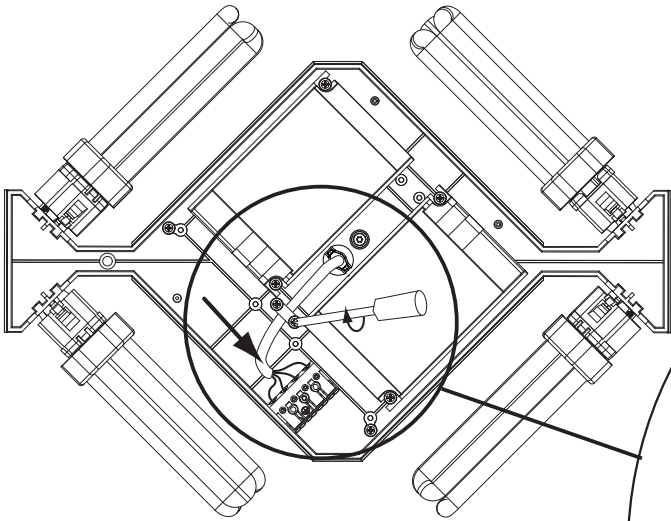
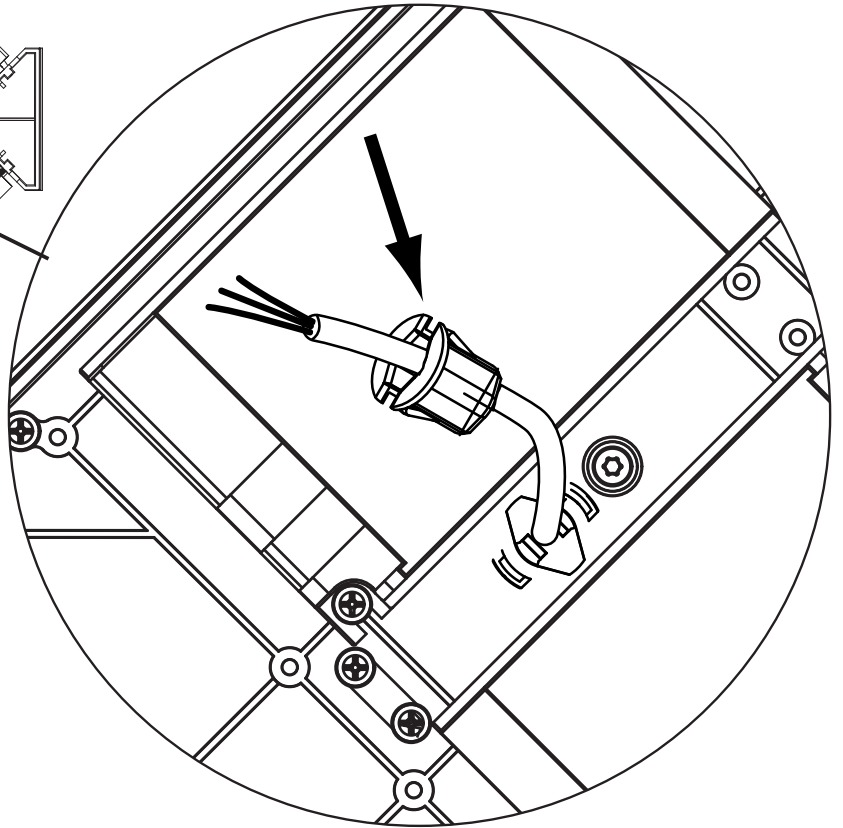
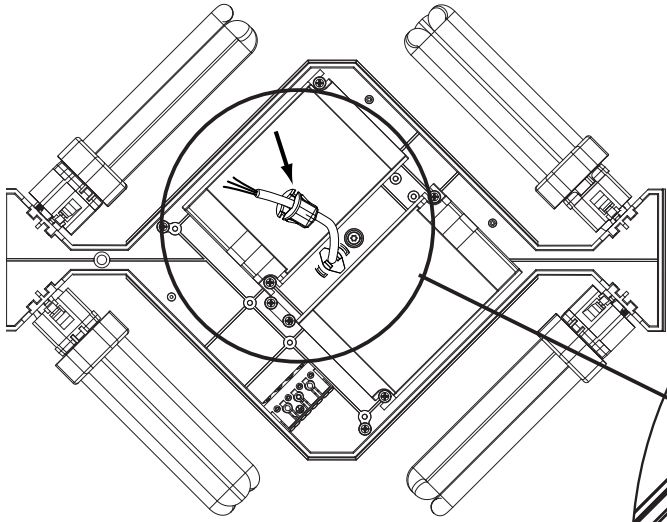



**BELUX AG**  
[www.belux.com](http://www.belux.com)