

SMALLSIZE

Pendelleuchte
Wall lamp
Applique
Wandlamp
Apparecchio da parete

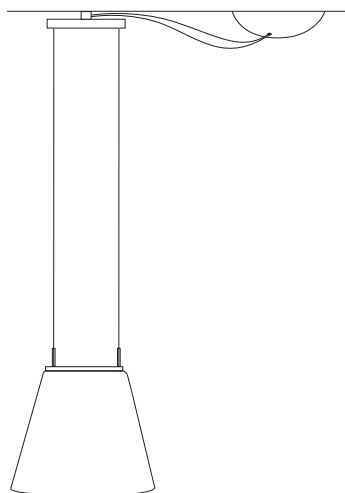

Montageanleitung
Assembly Instructions
Instruction de montage
Montagehandleiding
Istruzioni di montaggio



SMALLSIZE

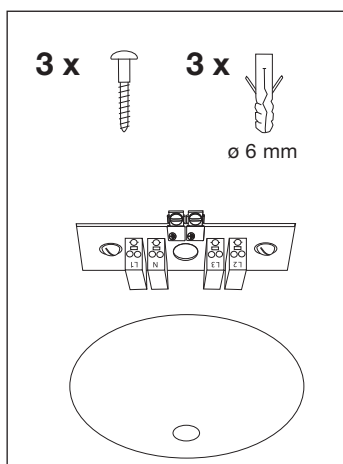
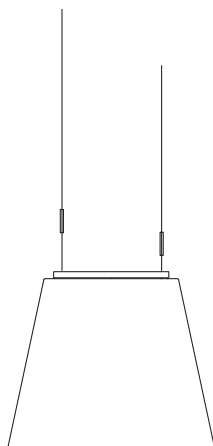
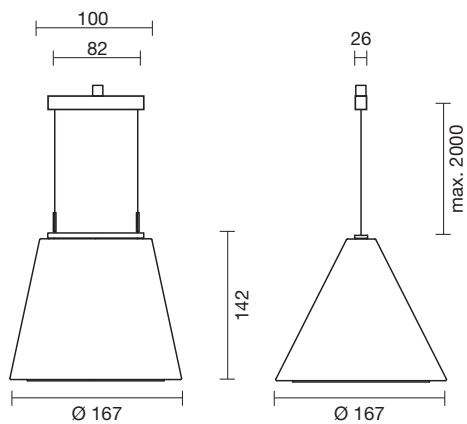

1 x SW2



1 x

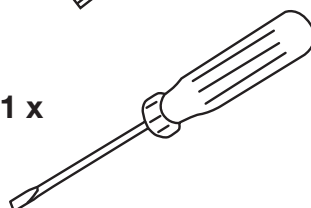

2 x



1

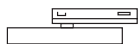
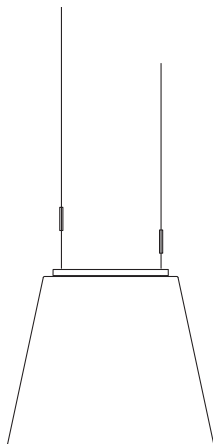

1 x SW2



1 x

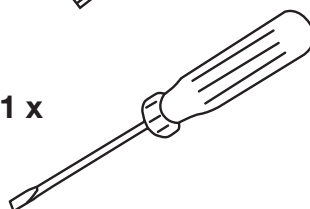

Technische Hinweise



- BELUX-Produkte ohne Stecker müssen ausschliesslich von einer autorisierten Fachkraft installiert werden.
- Wenn die Leuchte in Betrieb ist, besteht beim Glühmittel Verbrennungsgefahr!
- Beim Leuchtmittelwechsel besteht Verbrennungsgefahr.
- Bei Montage, Reinigung, Wartungsarbeiten und Leuchtmittelwechsel immer Stromzufuhr durch Entfernen der bauseitigen Sicherung unterbrechen!

Technical Information

- BELUX products without a power plug must be installed exclusively by an authorized expert.
- When switched on, the lamp may cause burns when touched!
- When changing the bulbs you are in danger of getting burned!
- During installation, cleaning, maintenance work and change of illuminants always interrupt the power supply by removing the respective circuit breaker!

Indications techniques

- Le luminaire ne peut être installé que par une main-d'oeuvre qualifiée autorisée.
- Lorsque la lampe est allumée, vous pouvez vous brûler avec l'ampoule!
- Le remplacement de sources lumineuses recèle un risque de brûlures!
- Lors du montage, du nettoyage, des travaux de maintenance et du remplacement des sources lumineuses, veuillez toujours couper le courant en retirant le fusible!



- Eingangsspannung 220-240V/50Hz

- Input voltage 220-240V/50Hz

- Tension d'entrée 220-240V 50/60Hz



- Leuchtmittel E14/max 60W OPAL

- Lamp E14/max 60W OPAL

- Ampoule E14/max 60W OPAL



- Leuchten nur mit handelsüblichen, nicht aggressiven Reinigungsmitteln reinigen.

- Use only commercially available non-aggressive cleaning agents for cleaning the lamps.

- Ne nettoyer les lampes qu'avec des nettoyeurs non agressifs en vente dans le commerce.



- Leuchte darf nicht im Freien verwendet werden ICE 417.

- (ICE 417) Lamp must not be used in the open

- (ICE 417) Ne pas utiliser la lampe à l'extérieur



- Schutzklasse II

- Safety class II

- Classe de protection II



- Technische Konformität gemäss EN-Richtlinien

- Technical conformity according to European Standard guidelines

- Conformité technique selon les directives EN

Technische aanwijzingen



- Armatuur mag uitsluitend door een erkend elektro-technisch installateur geïnstalleerd worden.
- Een brandende lamp is heet. Pas op voor verbrandingsgevaar!
- Bij het wisselen van het lichtmiddel bestaat verbrandingsgevaar!
- Onderbreek altijd de stroomtoevoer door verwijderen van de toestelzijdige stop bij de montage, reiniging, onderhoudswerk en het verwisselen van de gloeilamp!

Informazioni tecniche

- La lampada può essere installata solo da uno specialista.
- Pericolo di scottature! Non toccare la lampadina quando la lampada è accesa!
- Durante la sostituzione dei corpi luminosi sussiste il pericolo di combustione!
- In caso di interventi di installazione, la pulizia, manutenzione e sostituzione dei corpi luminosi interrompere sempre l'alimentazione elettrica eliminando la protezione prevista!



- Ingangsspanning 220-240V 50/60Hz

- Tensione di alimentazione 220-240V 50/60Hz



- Lamp E14/max 60W OPAL

- Lampadina E14/max 60W OPAL



- Reinig de lampen uitsluiten met normale in de handel verkrijgbare, niet agressieve reinigingsproducten.

- Pulire la lampada solamente con i normali detersivi non aggressivi che si trovano in commercio.



- (ICE 417) De lamp mag niet in openlucht gebruikt worden

- (ICE 417) La lampada non può essere utilizzata all'aperto



- Beschermingsklasse II

- Classe di protezione II



- Technische gelijkvormigheid volgens EN-richtlijnen

- Conformità tecnica secondo le Direttive EN



A

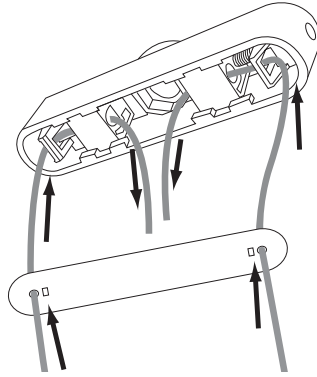

B

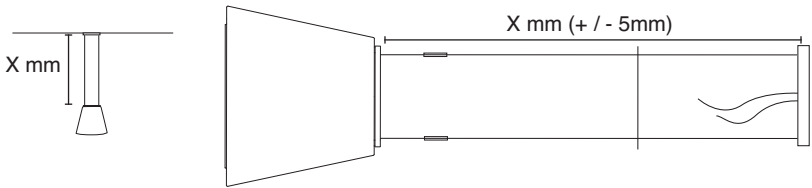

C

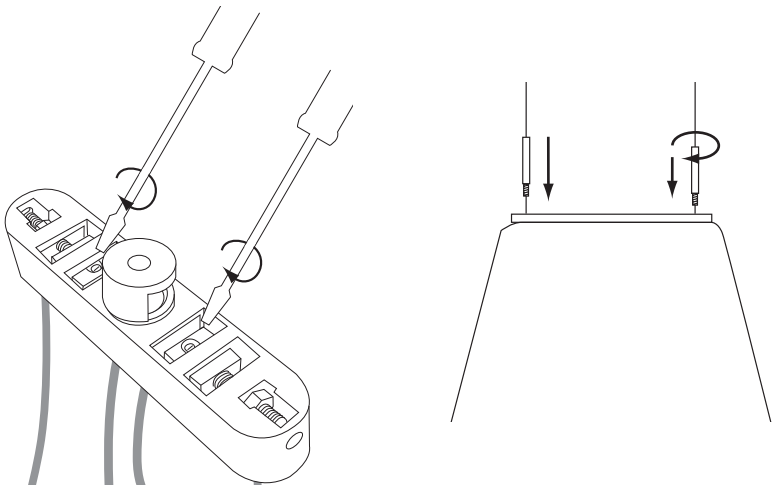

D

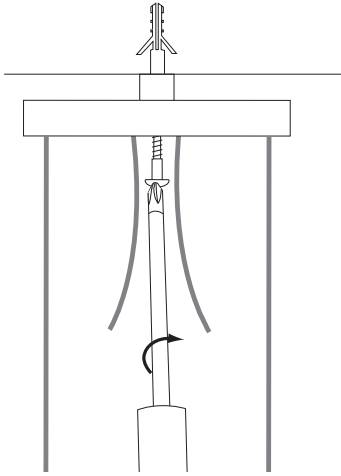

E

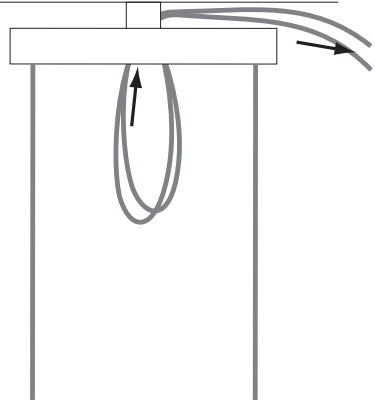

F

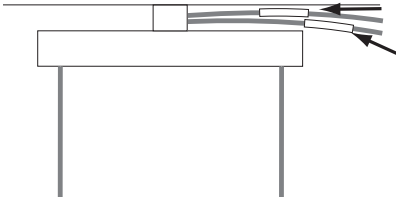

G

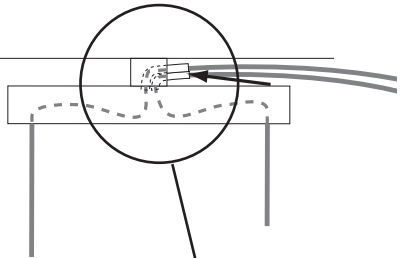

H

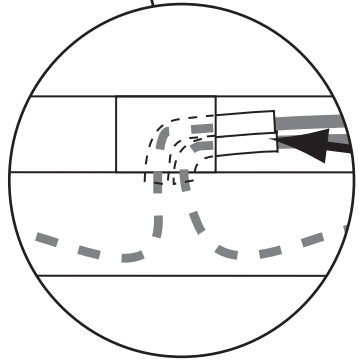
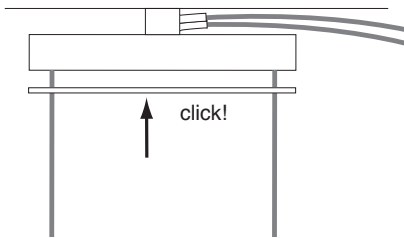

I

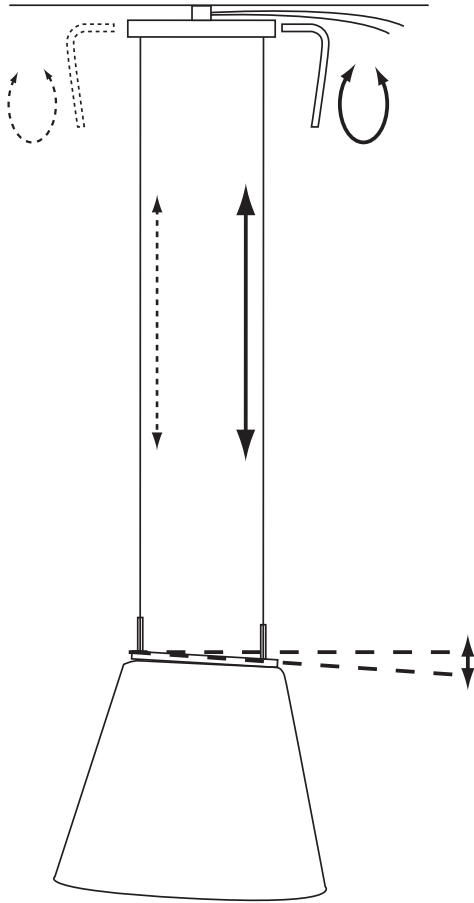

J

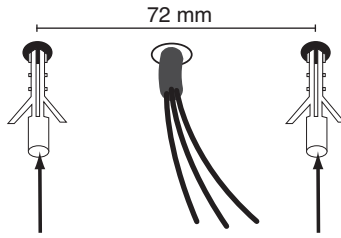

K

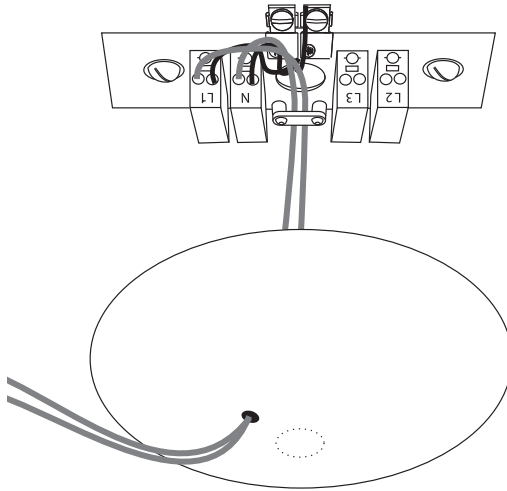

L

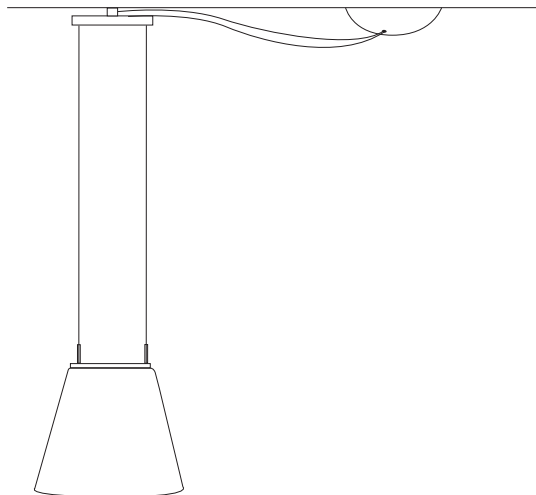

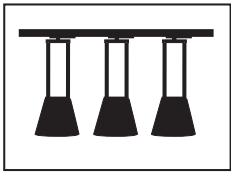

A

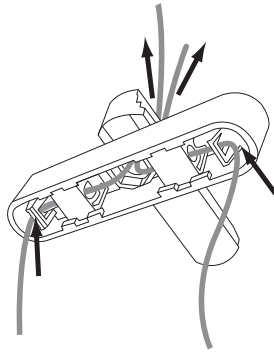

B

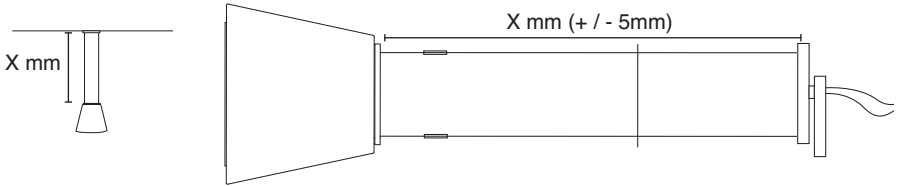

C

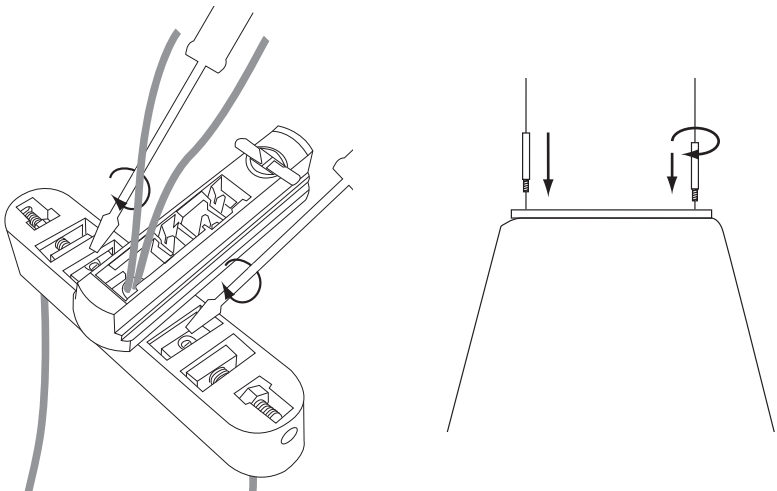

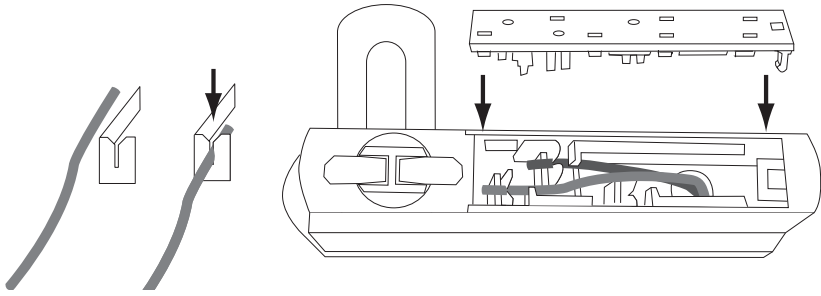
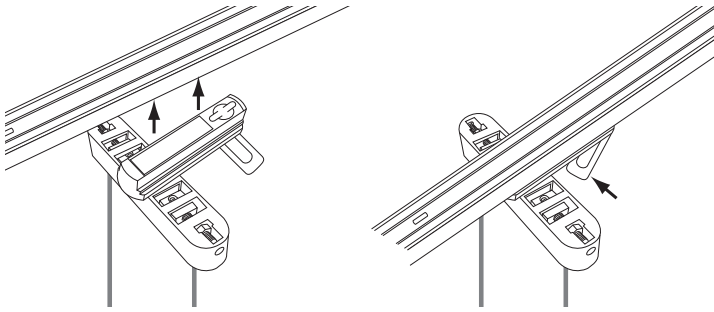
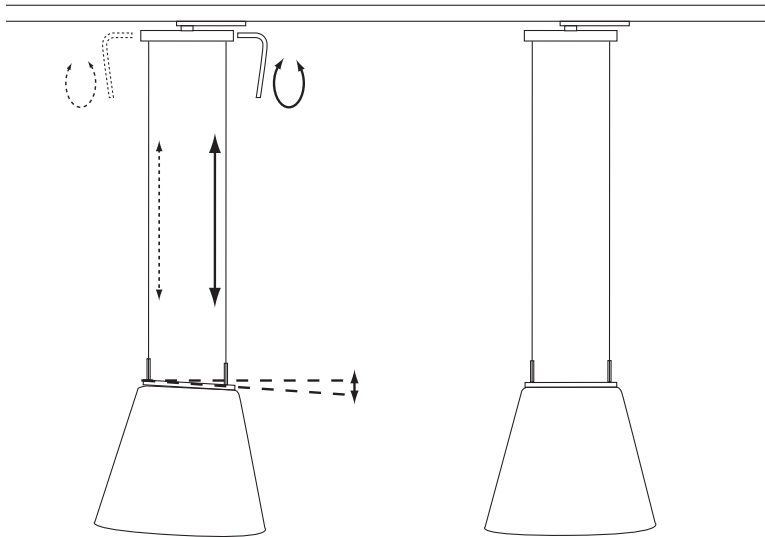
D**E****F**



BELUX AG
www.belux.com